

AUTOMATED SOLAR GRASS CUTTER

^{#1}Vinay R. Lonare, ^{#2}Rahul Sakat, ^{#3}Prof. Mrs. S. N. Chaphekar

¹vinaylonare@gmail.com

^{#123}DEPARTMENT OF ELECTRICAL ENGINEERING

PES's MODERN COLLEGE OF ENGINEERING,
PUNE -05



ABSTRACT

These days we are facing the problems like pollutions, power cut problem etc. In order to overcome these problems, we have thought about the device, which can be performing its functions without causing any of these problems. So we have thought of doing the project on cutting grass, this uses the renewable source of energy for its operation like solar energy. This project aims at developing a portable solar operated grass cutting device, as there is power shortage. So we have decided to make a solar energy operated device. Solar panel is connected to the battery. Then by connecting inverter to battery DC current is converted to AC current. This will run the AC motor. This motor is connected to blade shaft by the help of belt drive. This will rotate the blade in high speed, cut the grass. This device will help in building of eco-friendly system. Current technology commonly used for cutting the grass is by the manually handled device. In this paper used novel technology. So in this paper we are trying to make a daily purpose robot which is able to cut the grasses in Lawn. The system will have some automation work for guidance and other obstacle detection and the power source that is battery and a solar panel will be attached on the top of the robot because of this reduces the power problem.

Index Terms – Solar plate, ESP8266, Grass Cutter

ARTICLE INFO

Article History

Received: 1st June 2019

Received in revised form :

1st June 2019

Accepted: 4th June 2019

Published online :

5th June 2019

I. INTRODUCTION

A grass cutter is a machine that uses one or more revolving blades to cut a lawn to an even height. The blades may be powered either by hand; pushing the mower forward to operate the mechanical blade(s), or may have an electric motor or an internal combustion engine to spin their blades. There are several types of mowers, each suited to a particular scale and purpose. The smallest types are pushed by a human user and are suitable for small residential lawns and gardens. Riding mowers are larger than push mowers and are suitable for large lawns. The largest multi-gang mowers are mounted to tractors and are designed for large expanses of grass such as golf courses and municipal parks. But with advancement in technology and things being converted to mobile and automatic these days, transition from traditional hand-guided or ride-on mowers to automatic electric mowers is beginning to take place. In 2012, the growth of robotic grass cutter sales was 15 times that of the traditional styles. It is predicted that if this growth continues at this rate, automatic lawn mowers

may even surpass the sales of traditional lawn mowers in some places.

Automatic grass cutter is a machine that cut grass automatically. It can be stated as a machine or robot that helps people to do cutting grass work. The automatic grass cutter will do the cutting grass task with a preset setting by the user. Unlike other robotic lawn mowers on the market, this design requires no perimeter wires to maintain the robot within the lawn. Through an array of sensors, this robot will not only stay on the lawn, it will avoid and detect objects and humans.

The concept of grass cutter started during the 19th century whereby the design of grass cutter pulls by an animal such as cow or buffalo. This animal will pull the grass cutter and the grass cutter will do its work cutting the grass along the way the animal walk. Due to animal cannot work for a very long period, human start to reduce the usage of animal and building a machine. So various types of grass cutter have been built over the course of time. Mostly these have been manually operated but corresponding to the advancing of technology, latest lawn mowers work automatically. Sensor such as rain sensor,

light sensor, ultrasonic sensor and infrared sensor has widely been used nowadays to enable the grass cutter to be more intelligent and work efficiently.

Automated lawn mowers have been made available to the general public for over 30 years but its widespread or public use on the other hand has been limited mainly Due to the current costs of such devices. Existing technology sell at around £899 (INR 70000) or more (Grass cutter Reviews, 2011) and considering the fact that the manual versions of these devices, the standard lawn mowers, sell at around £86 (INR 5000) (Grass cutter Reviews, 2011). Although the cost of labor would need to be added to that of the equipment, the latter is still a current viable and affordable option for most consumers will benefit from.

The reason for robotic lawn mowers are an interesting area of research and work because there are numerous real-world benefits of having a machine that autonomously cuts grass, these include:

- Aid elderly users or those with disabilities who are unable to fulfil this task themselves.
- For users with a busy schedule and rarely find time to mow, etc.
- Working range is increased due to absence of main supply wires.
- It reduces human effort.

It is a device that can fit into just about everyone's lifestyle, therefore having a device that costs less, whilst accomplishing the same task as the higher end models is a great advantage in order to compete with the current market.

II. LITERATURE SURVEY

1. Design and Implementation of Autonomous Grass cutter Robot Controller

This paper basically focuses on designing an automated grass cutter controller which can use to mow the grass at lawns and playground. It used the concept of sense-act whereby it does not fully depend on the workspace surrounding. The automated grass cutter has the feature of detecting the grass. Besides that it has GPS system which allocated the path for the robot movement. Other than that, some sensor such as sonar sensor which use to detect obstacles, encoder to calculate the distance the grass cutter travel together with the GPS system. [1]

2. Design and Implementation of a Control Algorithm for an autonomous lawn mower

This paper discuss on the way of implementing GPS system for automated grass cutter path flow. Besides that it also stated there they used PID controller to increase the performance of the motor speed which can provide better flow. Besides that, their project also included encoder to calculate distance but their encode was made by magnetic and hall sensor which placed around the wheel and it calculate the number of magnetic field strength while moving which will convert the number of magnet to distance travelled. The grass cutter performance is being watch throughout the whole working process at the base station using wireless transmission. [2]

3. Modified Grass cutter Search Pattern for Areas Comprised of Weighted Regions

This paper discusses on the way the grass cutter move while it work. It used weightage spot or region to determine the correct way of path. With this technique, the grass cutter can find the most important place to cut the grass depending on the amount of weight comprised in order to cover the maximum area and also to minimize the time usage. The region with the most weight will be allocated first followed by the second weight and so on. This is some sort of guided path system whereby it move according to the weight given. With this technique, is able to achieve a good result on area coverage. [3]

4. Design and Modeling a Prototype of a Robotic Lawn Mower

This paper discuss on how to develop a robotic grass cutter with several functions. It objective is to build a grass cutter that do not go out of workspace, do not leave any uncut area, able to avoid collision and the most important that is the robot must be cheap and affordable to everyone. Basically it used PIC microcontroller to perform the grass cutter working process or to run the lawn mower. [4]

5. Survey of Robotic Lawn Mowers

This paper discusses different types of Robotic Lawn Mowers present in the market at present. It discusses different companies and their products and compares them with others.

III. BLOCK DIAGRAM

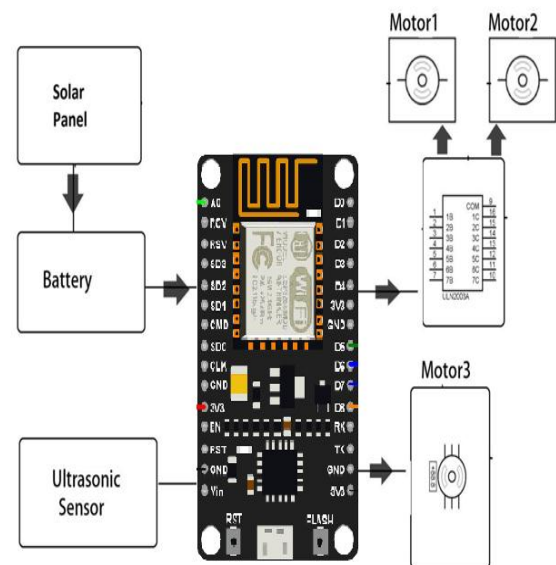

Fig 1. Block diagram

Component Used:

DC Motor

DC motor is a device that converts electrical form into mechanical form of energy. There are many kind of DC motor such as DC motor, separately excited DC motor and self-excited DC motor. DC motor was powered by DC current. There are various voltage input for DC motor and the common voltage input for DC motor are 3V, 5V, 12V, and 24V. There are advantages for DC motor which are the

DC motor perform better than AC motor, and DC motor provide excellent of controlling the speed.



Fig 2. DC Motor

Ultrasonic Sensor:

Ultrasonic sensor is a sensor that uses ultrasonic sound to detect range or distance of an object. This sensor can also act as a sensor to detect present or absent of an object. Due to ultrasonic is in the form of sound, a sort of energy, it can be used to calculate distance whereby the distance of the sound travel from the emitter to an object and reflect back to the receiver. Sound wave travel at speed of 340m/s. Figure 3 shows the ultrasonic sensor concept used to calculate the distance.

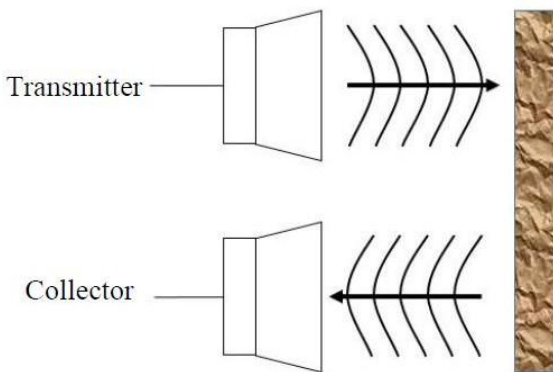

Fig 3: Ultrasonic Sensor Concept



Fig 4. Ultrasonic Sensor

ESP8266:

ESP-12E WiFi module is developed by Ai-thinker Team. core processor ESP8266 in smaller sizes of the module encapsulates Tensilica L106 integrates industry-leading ultra low power 32-bit MCU micro, with the 16-bit short mode, Clock speed support 80 MHz, 160 MHz, supports the RTOS, integrated Wi-Fi MAC/BB/RF/PA/LNA, on-board antenna. The module supports standard IEEE802.11 b/g/n agreement, complete TCP/IP protocol stack. Users can use the add modules to an existing device networking, or building a separate network controller. ESP8266 is high integration wireless SOCs, designed for space and power constrained mobile platform designers. It provides unsurpassed ability to embed Wi-Fi capabilities within other systems, or to function as a standalone application, with the lowest cost, and minimal space requirement.

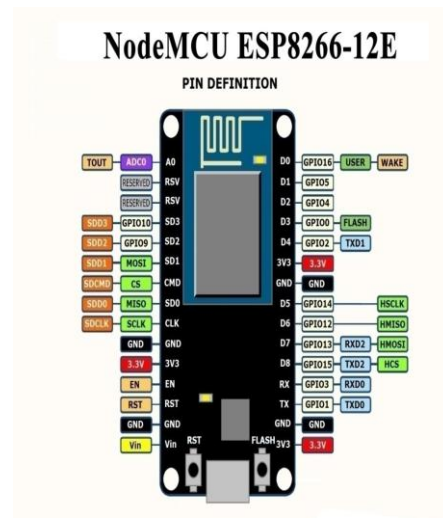

Fig 5. Wi-fi Module ESP8266

Cutter:

This will be used for the primary function of the mower i.e. to cut the grass. Depending on the design, more than one cutter can be used in synchronization as well. Also cutters with different shape or number of blades can be used for the purpose of getting the required cutting speed.

Battery:

It will provide the energy for the working of the robot. The battery of a two wheelers will be able to provide enough power to drive the robot for its working or independent multiple batteries can be used for better performance.

Wheels:

These will be required for the cause of the motion of the body of the robot. The choice of the wheels largely depends on the shape and size of the grass. It will also depend on the required ground clearance of the robot. As treads of the tires can contribute significantly to the performance of the mower, great caution is needed during the decision to choose the particular tires.

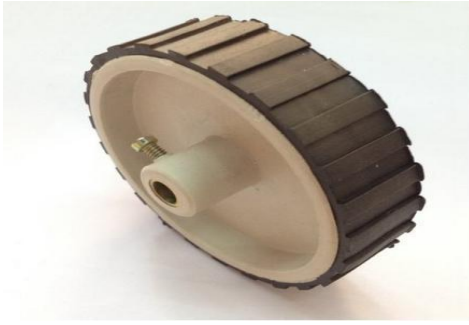

Fig 6. Wheel

IV. RESULT

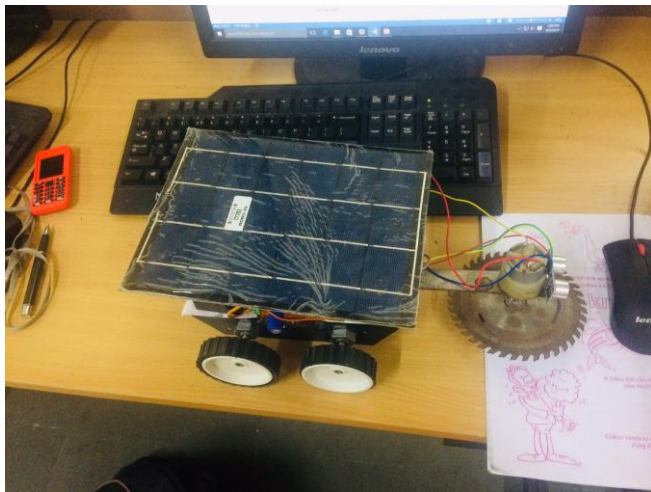

Fig 7. Top view Model setup

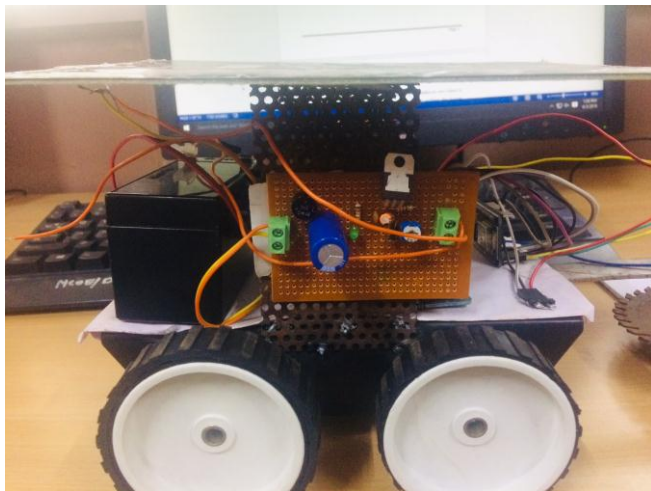

Fig 8. Side view

V. CONCLUSION

An automatic grass cutter with several features has been proposed. Several related works has been studied in order to gain idea on how to build an automatic lawn mower. Most research is on the robot path planning using variety technique. All the technique used are mainly aim for the shortest path, consume less energy.

Advantages:

As an automatic device, this grass cutter has many advantages, some of which are:

- It reduces human effort.
- It has simpler design than most commercial mowers.
- This type of mower is cheaper than commercial mowers.
- It has wider range more than conventional mechanical mowers due to absence of main supply wire.
- It aids elderly users or those with disabilities who are unable to fulfill this task themselves.

REFERENCES

1. M. Wasif (2011). Design and Implementation of Autonomous Lawn-Mower Robot Controller. 2011 7th International Conference. 5-6 September. Emerging Technologies (ICET), 1-5.
2. Smith, J., S. Campbell, and J. Morton. (2005). Design and Implementation of a Control Algorithm for an Autonomous Lawn Mower. Circuits and Systems. 7-10 August. Midwest Symposium, 456-459.
3. Ousingsawat, J. and M.G. Earl. Modified Lawn-Mower Search Pattern for Areas Comprised of Weighted Regions. American Control Conference. 9-13 July. 918- 923.
4. Mohammad Baloch, T. and K. Timothy Thien Ching. (2008). Design and modelling a prototype of a robotic lawn mower. Information Technology,. International Symposium. 25-28 August. 1-5.
5. Hicks, R.B. and Hall, E. A Survey of Robot Lawn Mowers. SPIE Intelligent Robotics and Computer Vision Conference.